

* = Maß durch Formkonizität nach unten verringert
Freimaß-Toleranz nach GTA13/5 DIN 1688
* = Measure by draught down ward reduced
General tolerance acc. GTA13/5 DIN 1688

Unterteil / base

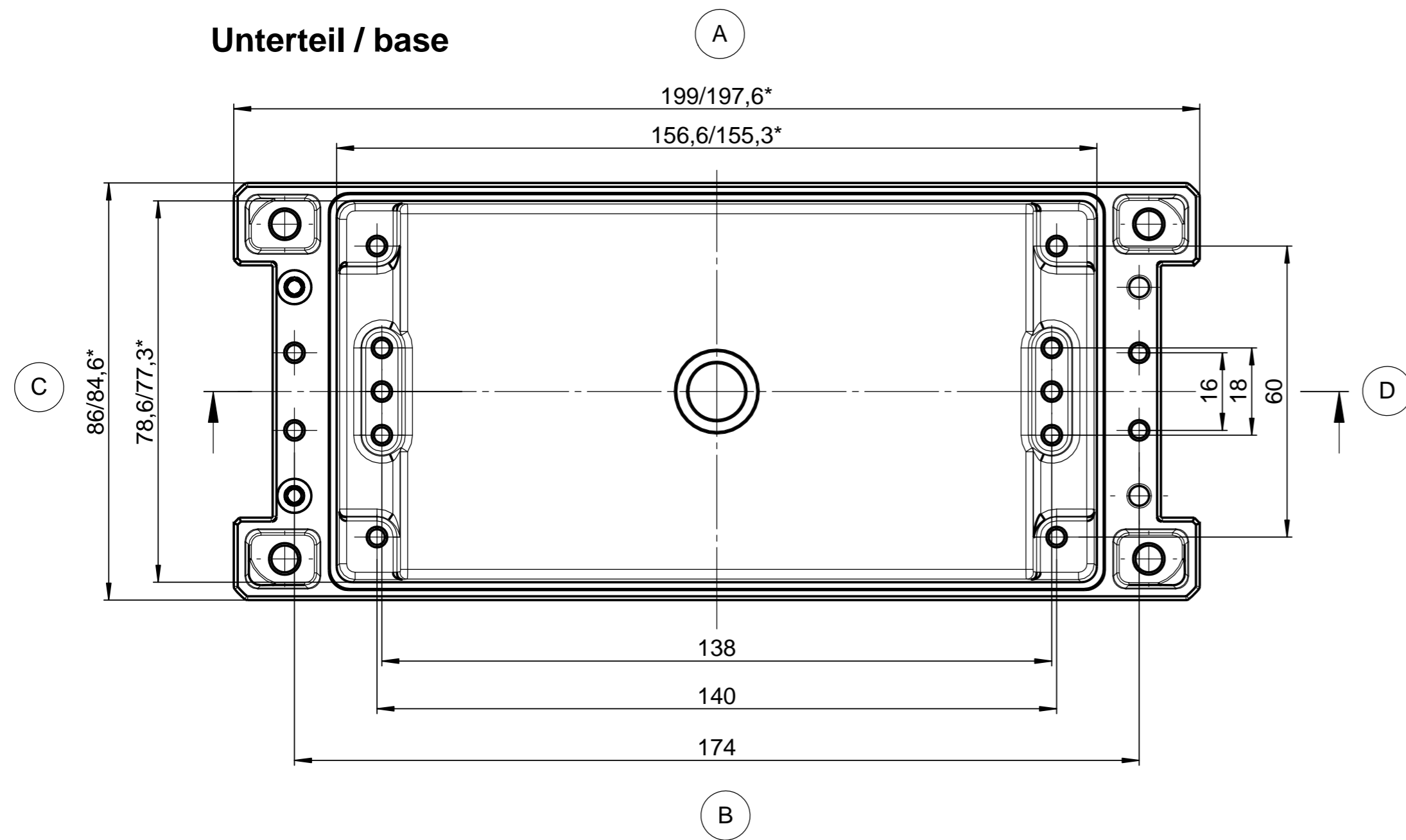

Deckel / lid

